

200 PSI WWP Bronze Check Valves

Fire Protection Valve • Horizontal Swing • Rubber Disc

200 PSI/13.8 Bar Non-Shock Cold Water



KT-403-W
Threaded

CONFORMS TO MSS SP-80

MATERIAL LIST

PART	SPECIFICATION
1. Bonnet	Bronze ASTM B 62 or B 584 Alloy C84400
2. Body	Bronze ASTM B 62 or B 584 Alloy C84400
3. Hinge Pin	Bronze ASTM B 140 Alloy C31400 or B 134 Alloy C23000
4. Disc Hanger	Bronze ASTM B 62
5. Hanger Nut	Bronze ASTM B 97 Alloy C65500 or Brass ASTM B 16
6. Disc Holder	Bronze ASTM B 62
7. Seat Disc	Nitrile (W) PTFE (Y)†
8. Seat Disc Nut	Brass ASTM B 16 or B 97 Alloy C65500
9. Hinge Pin Plug	Bronze ASTM B 140 Alloy C32000 (Not Shown)
*10. Seat Disc Washer	Stainless Steel

*Sizes ¾", 1", 1¼" and 1½" only.

†2½" and 3" size only.

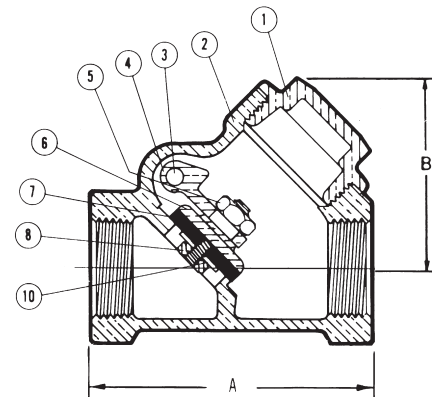

KT-403-W
NPT x NPT

DIMENSIONS—WEIGHTS—QUANTITIES

Size	Dimensions				Weight		Box Qty.	Master Ctn. Qty.
	A		B		Lbs.	Kg.		
In. mm.	In.	mm.	In.	mm.				
½ 15	2.44	62	1.69	43	.58	.26	10	50
¾ 20	2.94	75	1.88	48	.92	.42	10	50
1 25	3.56	90	2.31	59	1.55	.70	5	30
1¼ 32	4.19	106	2.69	68	2.32	1.05	5	20
1½ 40	4.50	114	2.94	75	3.00	1.36	2	10
2 50	5.25	133	3.81	97	4.87	2.21	2	10
2½ 65	8.00	203	5.06	129	11.48	5.22	1	5
3 80	9.25	235	6.25	159	17.53	7.97	1	4

Sizes 2½" and 3" supplied as T-433-Y with PTFE seat disc.

NIBCO check valves may be installed in both horizontal and vertical lines with upward flow or in any intermediate position.

WARNING - Valve must be installed downstream of receiver tank if used in line with reciprocating air compressor.