

Class 150 Ductile Iron Body Gate Valves

Raised Face Flanges • Bolted Bonnet • Outside Screw and Yoke • Solid Wedge • B 584 Bronze Trim

285 PSI/19.7 Bar Non-Shock Cold Working Pressure to -20° F to 100° F/-29° C to 38° C.

185 PSI/12.8 Bar Saturated Steam to 450°F/232°C ◆

CONFORMS TO MSS SP-128

MATERIAL LIST

PART	SPECIFICATION
1. Stem	Bronze ASTM B 371
2. Handwheel Nut	Bronze ASTM B 584
3. Identification Plate	Aluminum
4. Yoke Bushing	Bronze ASTM B 584
5. Handwheel	Iron ASTM A 126 Class B
6. Bonnet Cap Nut	Steel ASTM A 307
7. Bonnet Cap	Ductile Iron ASTM A 536
8. ¹ Bonnet	Ductile Iron ASTM A 395
9. Bonnet Cap Bolt	Steel ASTM A 307
10. Gland Follower Nut	Brass ASTM B 36
11. Gland Follower	Ductile Iron ASTM A 536
12. Packing Gland	Brass or Iron
13. Packing	PTFE Braided
14. Gland Follower Bolt	Steel ASTM A 307
15. Backseat Bushing	Bronze ASTM B 584
16. Body Nut	Steel ASTM A 307
17. Body Bolt	Steel ASTM A 307
18. Wedge Pin	Bronze ASTM B 371
19. Body	Ductile Iron ASTM A 395
20. ³ Seat Ring	Bronze ASTM B 584
21. Wedge Face Ring	Bronze ASTM B 584
22. ² Wedge	Ductile Iron ASTM A 395
23. Body Gasket	Synthetic Fibers
24. Stem Collar	Bronze ASTM B 371
25. Grease Fitting	Alemite 1743B (not shown)

¹ Sizes thru 8" made with Yoke Integral with Bonnet. 10" and 12" sizes made with separate Yoke Bolted to Bonnet.

² Sizes 2" thru 6" are all Bronze (31 Trim).

Sizes 8" thru 12" Ductile Iron Wedge with Bronze Wedge Face Rings (31 Trim).

³ Lugs may be removed at customer's request - POA.

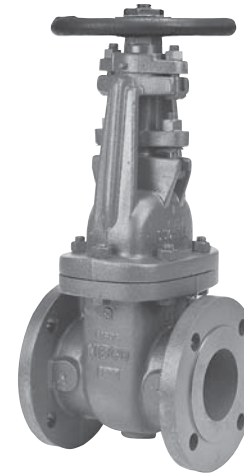

F-637-31
Flanged-Raised Face

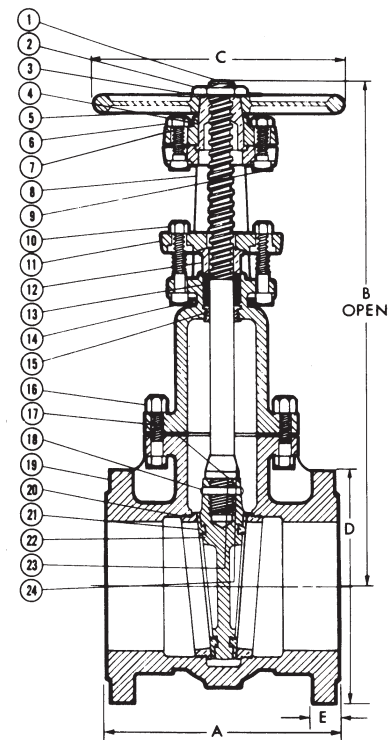

F-637-31
Flg x Flg

FREEZING WEATHER PRECAUTION: Subsequent to testing a piping system, valves should be left in an open position to allow complete drainage.

◆ For detailed Operating Pressure, refer to Pressure Temperature Chart on page 111.

DIMENSIONS—WEIGHTS—QUANTITIES

Size	Dimensions										Weight		
	A		B		C		D		E		Lbs.	Kg.	
In.	mm.	In.	mm.	In.	mm.	In.	mm.	In.	mm.	In.	mm.		
2	50	7.00	178	16.31	414	8.00	203	6.00	152	.63	16	41	19
2½	65	7.50	191	17.19	437	8.00	203	7.00	178	.69	17	55	25
3	80	8.00	203	19.50	495	8.00	203	7.50	191	.75	19	67	30
4	100	9.00	229	24.00	610	10.00	254	9.00	229	.94	24	107	48
5	125	10.00	254	27.13	689	10.00	254	10.00	254	.94	24	145	66
6	150	10.50	267	31.06	789	12.00	305	11.00	279	1.00	25	178	81
8	200	11.50	292	40.19	1021	14.00	356	13.50	343	1.13	29	309	140
10	250	13.00	330	48.25	1226	16.00	406	16.00	406	1.19	30	481	218
12	300	14.00	356	56.88	1445	18.00	457	19.00	483	1.25	32	706	320