

500 PSI WWP Iron Body Gate Valves

Fire Protection Valve • Bolted Bonnet • Outside Screw and Yoke •
Solid Wedge • Bronze Mounted • Class 250 Flanges

250 PSI/17.2 Bar Saturated Steam to 406° F/207° C

**500 PSI/34.5 Bar Non-Shock Cold Working Pressure
to -20° F to 150° F/-29° C to 66° C**

CONFORMS TO MSS SP-70 •

APPROVED BY THE NEW YORK CITY B.S.A. 143-69-SA
AT 350 PSI NON-SHOCK COLD WATER

MATERIAL LIST

| PART | SPECIFICATION |
|----------------------------------|----------------------------------------------------------------------|
| 1. Stem | Brass ASTM B 16 Alloy C36000 |
| 2. Handwheel Nut | Cast Bronze ASTM B 584 Alloy C84400 |
| 3. Identification Plate | Aluminum |
| 4. Yoke Bushing | Cast Bronze ASTM B 584 Alloy C84400 |
| 5. Handwheel | Cast Iron ASTM A 126 Class B |
| 6. Bonnet Cap Nut | Steel ASTM A 307 |
| 7. Bonnet Cap | Cast Iron ASTM A 126 Class B or Ductile Iron ASTM A 536 |
| 8. ¹ Bonnet | Cast Iron ASTM A 126 Class B |
| 9. Bonnet Cap Bolt | Steel ASTM A 307 |
| 10. Gland Follower Nut | Brass ASTM F 467 Alloy C27000 |
| 11. Gland Follower | Cast Iron ASTM A 126 Class B or Ductile Iron ASTM A 536 |
| 12. Packing Gland | Zinc Plated Powdered Iron ASTM B 783 or Brass ASTM B 16 |
| 13. Packing | PTFE Braided |
| 14. Gland Follower Bolt | Steel ASTM A 307 |
| 15. Backseat Bushing | Cast Bronze ASTM B 584 Alloy C84400 |
| 16. Body Nut | Steel ASTM A 307 |
| 17. Body Gasket | Reinforced Graphite |
| 18. Body Bolt | Steel ASTM A 307 |
| 19. Body | Cast Iron ASTM A 126 Class B |
| 20. Stem Collar | Brass ASTM B 16 Alloy C36000 |
| 21. ² Wedge | Cast Iron ASTM A 126 Class B |
| 22. ³ Wedge Nut | Cast Bronze ASTM B 584 Alloy C84400 |
| 23. Wedge Pin | Silicon Bronze ASTM B 371 Alloy C69400 or ASTM B 140 Alloy C31400 |
| 24. Seat Ring | Cast Bronze ASTM B 584 Alloy C84400 |
| 25. ² Wedge Face Ring | Cast Bronze ASTM B 584 Alloy C84400 |

¹Sizes 2" thru 8" made with Yoke Integral with Bonnet. Sizes 8" thru 12" made with separate Yoke Bolted to Bonnet.

²Wedge construction – 2" thru 3" all bronze.
– 4" thru 12" Cast Iron with Bronze Wedge Face Rings.

³Bronze Wedge Nuts used on sizes 5" thru 12".

DIMENSIONS—WEIGHTS—QUANTITIES

| Size | Dimensions | | | | | | | | | | F-667-O Weight | | |
|---------|------------|-------|-----|-------|------|-----|-----|-------|-----|------|----------------|------|-----|
| | A | | B | | C | | D | | E | | Lbs. | Kg. | |
| In. mm. | In. | mm. | In. | mm. | In. | mm. | In. | mm. | In. | mm. | | | |
| 2 | 50 | 8.50 | 216 | 16.00 | 406 | 8 | 203 | 6.50 | 165 | .88 | 22 | 56 | 25 |
| 2½ | 65 | 9.50 | 241 | 18.44 | 468 | 8 | 203 | 7.50 | 191 | 1.00 | 25 | 74 | 34 |
| 3 | 80 | 11.13 | 283 | 20.50 | 521 | 10 | 254 | 8.25 | 210 | 1.13 | 29 | 122 | 55 |
| 4 | 100 | 12.00 | 305 | 27.00 | 686 | 12 | 305 | 10.00 | 254 | 1.25 | 32 | 193 | 87 |
| 5 | 125 | 15.00 | 381 | 31.50 | 800 | 12 | 305 | 11.00 | 279 | 1.38 | 35 | 297 | 135 |
| 6 | 150 | 15.88 | 403 | 33.00 | 838 | 16 | 406 | 12.50 | 318 | 1.44 | 37 | 411 | 187 |
| 8 | 200 | 16.50 | 419 | 45.50 | 1156 | 16 | 406 | 15.00 | 381 | 1.63 | 41 | 637 | 289 |
| 10 | 250 | 18.00 | 457 | 56.00 | 1422 | 20 | 508 | 17.50 | 445 | 1.88 | 48 | 897 | 407 |
| 12 | 300 | 19.75 | 502 | 60.00 | 1524 | 20 | 508 | 20.50 | 521 | 2.00 | 51 | 1172 | 532 |



F-667-O
Flanged

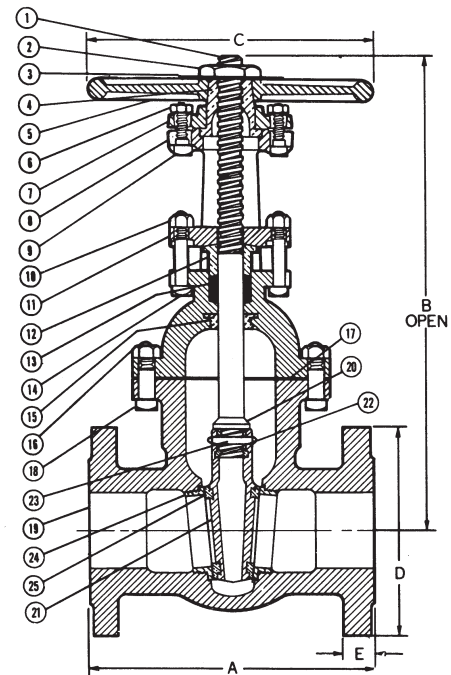

F-667-O
Flg x Flg

FREEZING WEATHER PRECAUTION: Subsequent to testing a piping system, valves should be left in an open position to allow complete drainage.